

POWERLINE[®]

GENERATORS

Model KS1050 – 10.5 kWe*

Frontier
POWER PRODUCTS
www.frontierpower.com

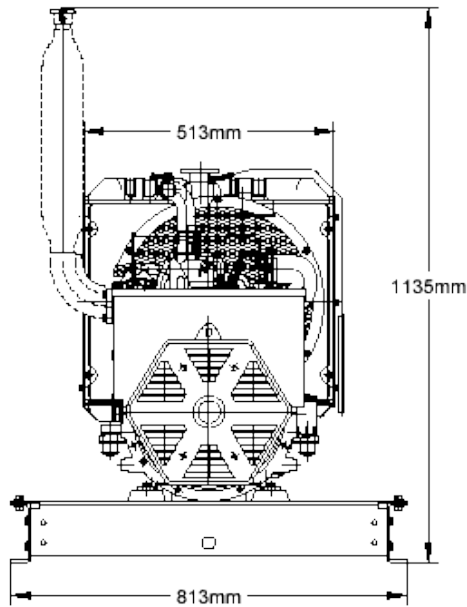

Approx dry weight without battery:
- 290 kg (638 lbs)

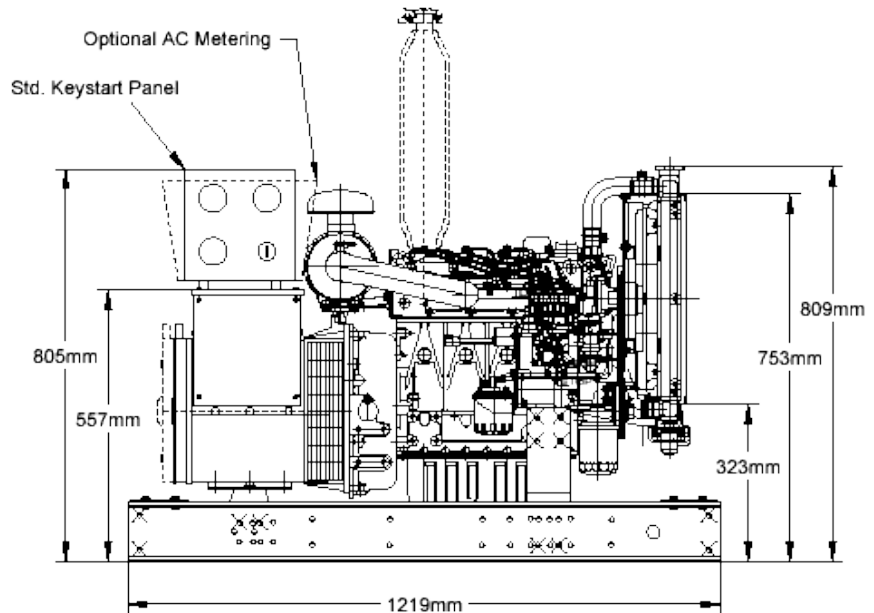

*This drawing is for general information only – not for installation purposes.
Specifications, dimensions or ratings may be changed without notice.*

General Information*

- The generator set rating is 9.5 kilowatts prime power output and 10.5 kilowatts intermittent power output. These ratings are based upon standard rating conditions. It may be necessary to derate the output for altitudes above 1000' (300 meters) or for ambient temperatures above 104°F (40°C). Please contact Frontier Power Products for details on ratings criteria for the engine and generator or for derate information.
- The engine and brushless four pole AC generator are directly coupled and mounted on a rugged steel base frame. All components are suitable for prime or intermittent usage.
- The entire set is thoroughly load tested prior to shipment.

Standard Engine

- Kubota diesel model V1305BG. In-line, four cylinder engine with full flow, replaceable lube oil, fuel and air filters. Mechanical speed governing provides +/- 3 to 5% speed regulation, no load to full load.

- Liquid cooled with industrial grade radiator and belt driven blower fan.
- SAE housing and flywheel directly connected to the single bearing generator.

Standard Generator

- Newage Stamford brushless, four pole (1800 rpm) generator.
- Solid state, +/- 1½% automatic voltage regulation.
- CSA approved construction.

Standard Controls and Accessories

- Key start panel with oil pressure, coolant temperature, hour meter and glow plug indicator, resettable DC breaker protection
- Manual safety shutdown over-ride, fuse protection.
- Automatic safety shutdowns, energized-to-run, for low oil pressure/high coolant temperature.
- Four anti-vibration mounts between generator set and base frame.
- Electric fuel transfer and priming pump (12 VDC).
- Battery rack and cables (no battery) for 12 VDC starting system. (Optional battery available)

POWERLINE KS1050 Specifications

Engine Technical Information

| | |
|----------------------|----------------------------------|
| Manufacturer | Kubota |
| Model | V1305BG |
| Cylinders | Four |
| Bore X Stroke | 76mm X 73.6mm (2.99" X 2.90") |
| Displacement | 1,335 cc (81.47 c.i.d.) |
| Output, intermittent | 13.0 kWm (17.5 HP) |
| Output, continuous | 11.5 kWm (15.5 HP) |
| Comp. ratio | 22:1 |
| Engine weight | 127 kg (280 lbs.) dry |

Fuel System

| | |
|-----------------|-------------------------|
| Fuel type | #2 Diesel |
| Injection pump | Bosch PFR MD type |
| Injectors | Bosch DN "IDI" |
| Transfer pump | Electric, 12VDC |
| Fuel lift | 1 meter (3.3 ft.) |
| Suction fitting | 5/16" push-on |
| Return fitting | 3/16" push-on |
| Fuel use @ 100% | 3.9 litre/hr. @ 10.5 kW |
| Fuel use @ 75% | 3.0 litre/hr. @ 7.9 kW |
| Fuel use @ 50% | 1.6 litre/hr. @ 5.3 kW |

Actual fuel consumption varies with site conditions and fuel energy content.

Lube Oil System

| | |
|-------------------|-----------------------------------|
| Grade | API "CD/CE" |
| > 25°C (77°F) | SAE30, SAE10W-30 or SAE10W-40 |
| 0°-25°C(32°-77°F) | SAE20, SAE10W-30 or SAE10W-40 |
| < 0°C (32°F) | SAE10W, SAE10W-30 or SAE10W-40 |
| Capacity | 6.0 liters (1.6 US gal.) |
| Filter | Full flow, spin-on |

Air Intake System

| | |
|-----------------------------|--------------------------------------|
| Filter | Replaceable element |
| Combustion air @1800 rpm | 1.28 m ³ /min. (45.4 cfm) |
| Restriction | 500mm (20") max.(H ₂ O) |

DC Electrical System

| | |
|------------------|------------------------|
| Starter | 12V, 1.2 kW |
| Alternator | 12V, 360 W |
| Glow plug | QGS type |
| Battery required | 12V 650 CCA @ 0°C min. |
| Run solenoid | 12V, ETR |

Cooling System

| | |
|----------------------|-----------------------------|
| Radiator | Finned tube type |
| Material | Copper core, soldered tanks |
| Pressure | 88 kPa (12.9 psi) max |
| Fan type | Blower, Nylon |
| Water pump | Gear case mounted |
| Type | Centrifugal, belt drive |
| Thermostat | Wax pellet type |
| Stat. cracking temp. | 71°C (160°F) |

Cooling System, cont'd.

| | |
|--|--|
| Fully open stat. temp. | 85°C (185°F) |
| Recommended coolant | 50/50* |
| <i>*Use low silicate ethylene glycol and high quality water. Consult manufacturer for details.</i> | |
| Air-to-boil @ 10.5 kW | 50°C (122°F) |
| Cooling air required | 29.3 m ³ /min (1040 ft ³ /min) |

Exhaust System

| | |
|--------------|------------------------|
| Muffler type | Industrial grade |
| Mounting | Vertical with rain cap |
| Restriction | 38 mm (1.5") Hg max. |

Noise Level @ 1 m (3.3')

Levels are with industrial grade muffler and open (no enclosure) configuration.

| | |
|-------------------|------------|
| Full load, inter. | 82.5 dB(A) |
| Full load, prime | 82.3 dB(A) |
| No load | 81.0 dB(A) |

Generator Technical Information

| | |
|------------------|--|
| Manufacturer | Newage/Stamford |
| Model | BCI164 |
| Construction | Four pole, brushless Open drip-proof (IP23) Single bearing |
| Weight | 107 kg (190 lbs.) |
| Cooling air flow | 5.4 m ³ /min (190 cfm) |
| Leads | 4 or 12, application dependent |

60 Hz. voltages and ratings (prime/intermittent)

- 9.5/10.5 kW, 9.5/10.5 kVA @ 115/230 1 phase
 - 9.5/10.5 kW, 11.9/13.1 kVA @ 120/208 3 phase
 - 9.5/10.5 kW, 11.9/13.1 kVA @ 277/480 3 phase
- Other voltages and 50 Hz ratings are available.*

| | |
|-------------------------|---|
| Power Factor | Single ph. ratings @ 1.0 PF Three ph. ratings @ 0.8 PF |
| Voltage regulation | SX460 solid state +/- 1½% no load to full load |
| Temperature rise | 105°C rise Prime (40°C ambient) 125°C rise Intermit. (40°C) |
| Telephone. interference | TIF < 50 |
| Winding pitch | Two thirds |
| Control system | Self excited |
| Inrush examples | 31 kVA @ 480V @ 30% dip 25 kVA @ 208V @ 30% dip |

Ancillary Equipment

| | |
|-----------|-----------------------------------|
| Mounting | Steel base with mounting holes |
| Isolators | Four composite mounts |

Please see the comprehensive option list.



CSA approved construction

Frontier
POWER PRODUCTS

www.frontierpower.com

Delta, BC, Canada (604) 946-5531
Edmonton, AB, Canada (780) 455-2260
Calgary, AB, Canada (403) 720-3735