

S6R2

OUTPUT · MARINE GEN-DRIVE · 485~640 kW
OUTPUT · MARINE PROPULSION · 597~818 HP

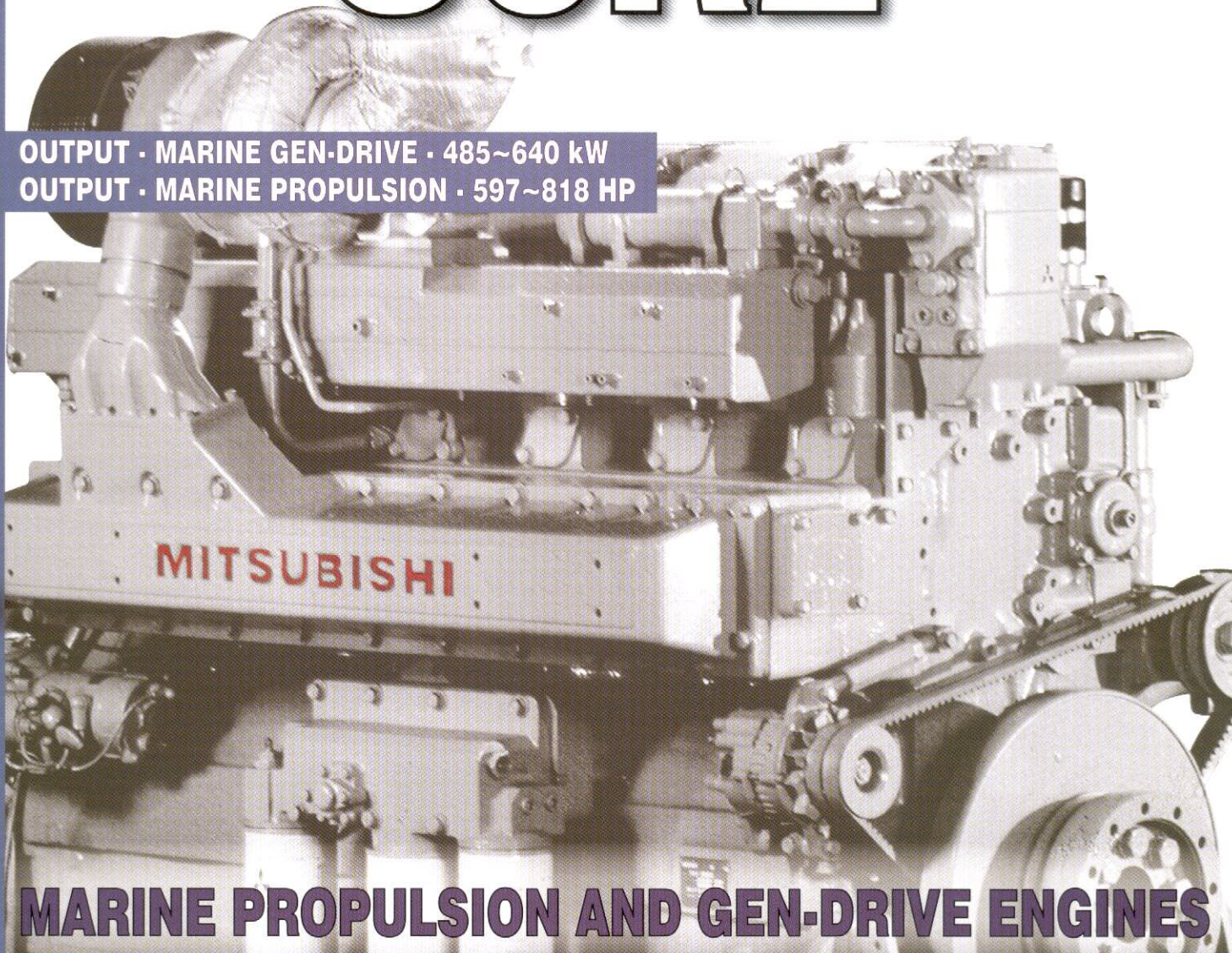

MARINE PROPULSION AND GEN-DRIVE ENGINES

Economic Operation

All Mitsubishi engines are designed and built to deliver performance, dependability and fuel efficiency. From the combustion chamber design to the fuel injection technology, to the turbocharger and the advanced cooling system...everything has been perfectly balanced to provide highly reliable operation and optimum fuel consumption across the entire power curve.

Easy Maintenance

With Mitsubishi's S6R2 marine engine, maintenance is very easy. Each cylinder has its own cylinder head and the engine has large inspection covers on the crankcase and oil pan. No auxiliary component requires separate lubrication, whether it's the fuel injection pump, the governor, the water pump or the turbocharger.

Approved by All Major Classification Societies

At our ISO certified manufacturing facilities, every Mitsubishi S6R2 diesel engine is built to meet the highest quality standards, as recognized by Lloyd's Register of Shipping and other major international marine classification societies.

Environmental Compatibility

Mitsubishi offers a full compliment of engines meeting both IMO and EPA emissions standards.

Local Support Around The Globe

A team of support specialists is available worldwide to ensure that service and maintenance are performed without delay.

MITSUBISHI ENGINE NORTH AMERICA, INC.
1250 GREENBRIAR DRIVE, SUITE E, ADDISON, IL 60101
P: 630.268.0750 F: 630.268.9293 www.mitsubishi-engine.com



mitsubishi MARINE

S6R2

-Y1MPTA

-Y1MPTK

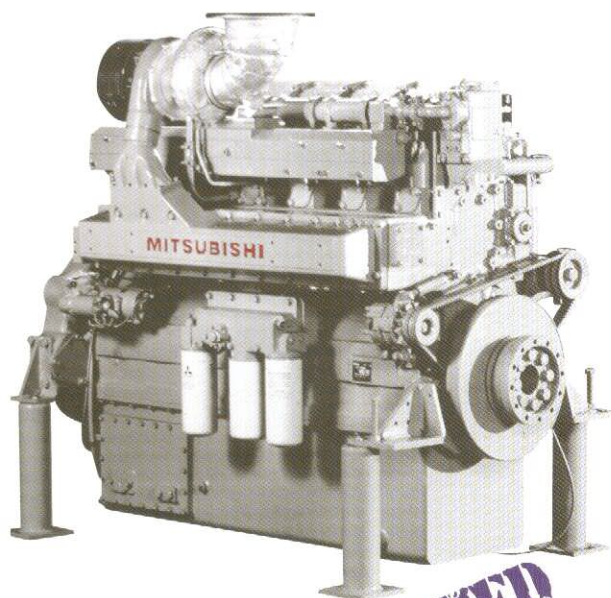

EPA CERTIFIED

Type	4-cycle, watercooled, turbocharged diesel engine MPTA with aftercooler, cooled by engine jacket water MPTK with intercooler, cooled by (sea) water of max 32°C	
Combustion System	Direct Injection	
Cylinder Arrangement	In-Line, 6-Cylinder	
Bore x Stroke - inches (mm)	6.69 (170) x 8.66 (220)	
Total Displacement - in ³ (ltr)	1,828 (29.96)	
Compression Ratio	14 : 1	
Rotation	SAE Standard (Counter-Clockwise Viewed from Flywheel End)	
Starting System	Electric Motor, 24 Volt - 7.5kW	
Flywheel	SAE 18	
Flywheel Housing	SAE #0	
Fuel Oil	ASTM D975, No. 1-D, No. 2-D	
Dry Weight - lbs (kg)	6417 (2910)	6527 (2960)

Output Marine Gen-Drive



HP (kWm) @ RPM	HP (kWm) @ RPM
650 (485) @ 1200	670 (500) @ 1200
798 (595) @ 1500	858 (640) @ 1500

Output Marine Propulsion



HP (kWm) @ RPM	HP (kWm) @ RPM
597 (445) @ 1350	643 (480) @ 1350
657 (490) @ 1400	710 (530) @ 1400
757 (565) @ 1500	818 (610) @ 1500

Outside Dimensions

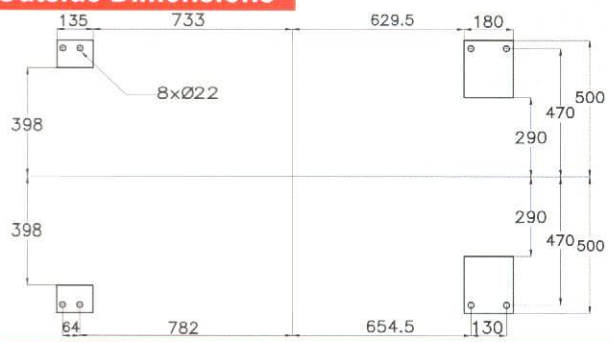

Dimensions in millimeters (1 inch = 25.4mm)

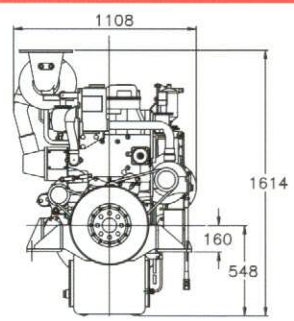
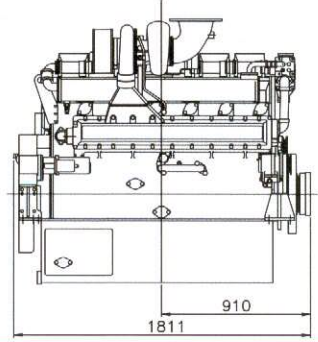

Standard Engine Equipment

Fuel System
Flexible fuel supply and return hoses, fuel feed pumps, fuel filters, fuel injection pumps, fuel injectors, overflow valve

Lubricating Oil System
Wet type oil pan with inspection covers, oil pressure pump, full-flow lubricating oil filters, by-pass filter, oil cooler with thermostat, piston cooling through oil injectors

Cooling System
Fresh water pump, thermostats with by-pass

24 Volt Electric System Earth Floated
Starter motor, battery charging alternator (35 amp), energize-to-stop (ETS) stop solenoid

Air Intake and Exhaust System
Mitsubishi turbochargers with vertical exhaust outlet, air inlet silencers with pre-cleaner, inlet air aftercooler or intercoolers, inlet manifolds, exhaust

manifolds, individual cylinder heads for easy service and maintenance, 4-valve cylinder head design for high efficiency and low emissions

General
Hydraulic Woodward PSG governor with oil supply system, mounting brackets, flywheel and housing SAE standard, torsional vibration damper, parts catalog and owners manual

Distributed By: