

NATURAL GAS ENGINE

KUBOTA DG SERIES (3-cylinder)

DG972-E2

3
EPA Phase

RATED POWER

17.6kW@3600rpm



Photograph may show non-standard equipment.

PERFORMANCE CURVE

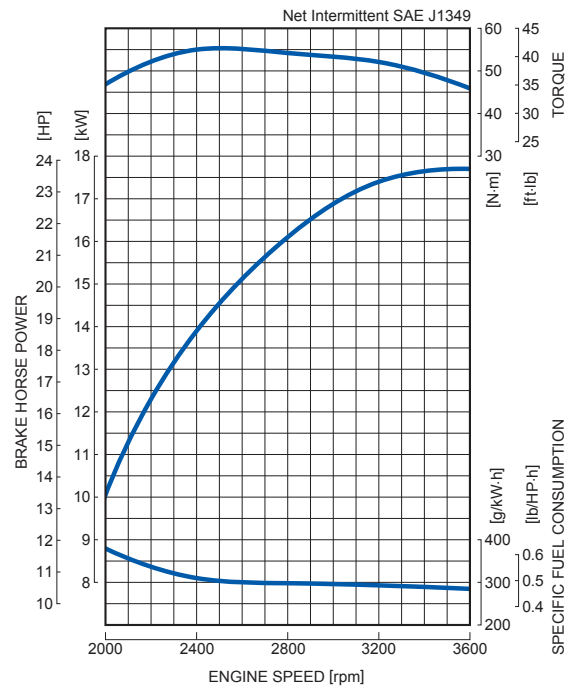

FEATURES and BENEFITS

New Engine Series

- The Kubota DG Series offers a new solution to the increasing needs for natural gas engine. The diesel engine based Kubota DG Series gives users the same foot-print, reliability and durability of D902, WG972 acknowledged as the world's top quality small industrial engines.
- Kubota offers SAE Flywheel Housing and Rear End Plate specifications for the DG972 engine. These options offer users flexible Power Take Off (PTO) choices.
- The Kubota DG Series is designed to endure use outdoors under severe environment. This series is equipped with a bypass breather tube to avoid freezing below zero.

Emission

- Kubota DG Series complies with EPA Phase3 Emissions Regulations. EPA regulation is one of the most stringent emissions regulations in the world.

Best Fuel System

- Specialized for Natural Gas use, the DG972 engine eliminated the carburetor, regulator and a fuel filter parts, which are only necessary for Gasoline or LPG use. Also, Kubota adopts the best jet set and the ignition timing that provides the best engine performance in severe conditions.

Ease maintenance cost and time

- Mechanical governor system will contribute to lower maintenance cost and prevents users from having to deal with complicated electric maintenance. Moreover, water resistant spark plug caps are adopted for outdoor use.

Application

- Stationary use only.

GENERAL SPECIFICATION

Model		DG972-E2
Emission Regulation		EPA Phase3
Type		Vertical 4-cycle Liquid Cooled Natural Gas
Number of Cylinders		3
Bore	mm (in)	74.5 (2.93)
Stroke	mm (in)	73.6 (2.9)
Displacement	L (cu.in)	0.962 (58.70)
Fuel		Natural Gas
Intake System		Naturally Aspirated
Maximum Speed	rpm	3600
Output: Net Intermittent	kW	17.6
	hp	23.6
	ps	23.9
Direction of Rotation		Counterclockwise Viewed on Flywheel
Oil Pan Capacity	L (gal)	3.7 (0.98)
Starter Capacity	V-kW	12-1.0
Alternator Capacity	V-A	12-40
Length	mm (in)	525.5 (20.69)* ¹ / 452.5 (17.81)* ²
Width	mm (in)	415.4 (16.35)
Height (1)	mm (in)	502.5 (19.78)
Height (2)	mm (in)	159.0 (6.26)
Dry Weight	kg (lb)	95.4 (210.3)* ¹ / 72.0 (158.7)* ²

*Specification is subject to change without notice.

*Output: Net Intermittent SAE J1349

*Dry weight is according to Kubota's standard specification. When specification varies, the weight will vary accordingly.

*¹ with SAE Flywheel and Housing

*² with Rear End Plate

DIMENSIONS

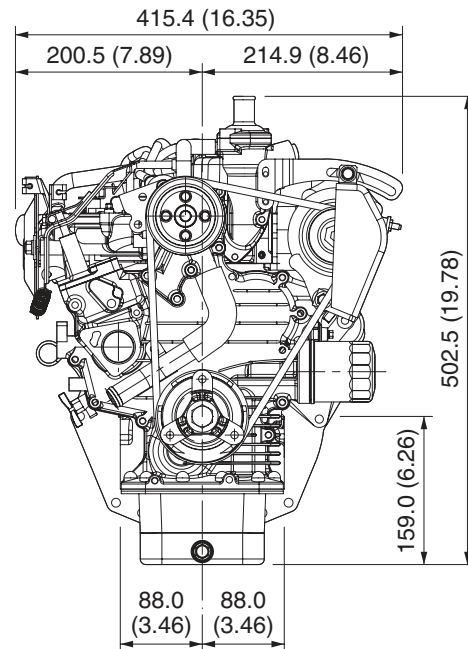
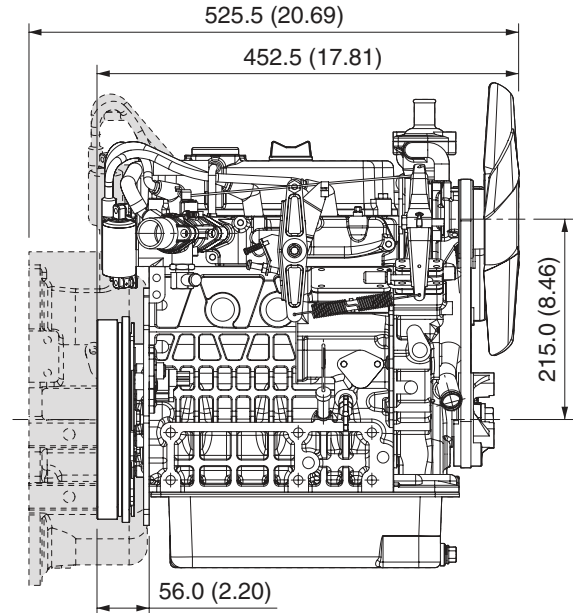

KUBOTA Engine America Corporation

505 Schelster Road, Lincolnshire, IL 60069

Phone: 847-955-2500 Fax: 847-955-2699

www.kubotaengine.com