

INDUSTRIAL DUALFUEL ENGINE

KUBOTA WG SERIES (3-cylinder)

WG752-GL-E3



RATED POWER

18.3kW@3600rpm (GAS)
17.5kW@3600rpm (LPG)



Photographs may show non-standard equipment.

PERFORMANCE CURVE

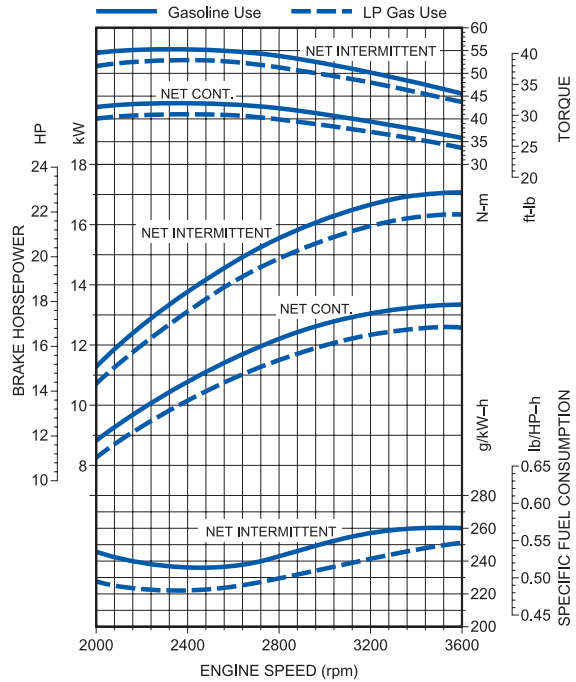

FEATURES and BENEFITS

Emission

- Kubota's WG752-G/GL-E3 engine has been designed to comply with two of the strictest emission regulations: EPA Phase3 and CARB Tier3.

Fuel Flexibility

- Installation compatibility between SI and CI engines is a good solution for customers who need fuel flexibility for their products. The Kubota WG Series has a gasoline version and a dual fuel (gasoline and LPG) version. Also available is a DG Series(*) natural gas version.

(*)The DG Series is compliant with the EPA Phase3 emission regulation only.

Durability and Reliability

- Kubota's WG Series small SI engines are designed after the Kubota Super Mini Series diesel (CI) engines, which are known worldwide as reliable industrial engines. The new WG Series engines provide an easy transition from the previous Tier models by leaving the same footprint while still offering excellent performance.

GENERAL SPECIFICATION

Model		WG752-GL-E3		
Emission Regulation		EPA Phase3, CARB Tier3		
Type		Vertical, Liquid-Cooled 4-cycle engine		
		Gasoline use	LPG use	
Number of Cylinders		3		
Bore	mm (in)	68 (2.68)		
Stroke	mm (in)	68 (2.68)		
Displacement	L (cu.in)	0.740 (45.2)		
Intake System		Naturally Aspirated		
Maximum Speed	rpm	3600		
Output: Gross Intermittent		kW	18.3	17.5
		hp	24.5	23.5
		ps	24.9	23.8
Lubricating oil capacity	L (gal)	3.25 (0.86)		
Starter Capacity	V-kW	12-0.7		
Alternator Capacity	V-A	12-14		
Direction of Rotation		Counterclockwise (viewed from the flywheel side)		
Length	mm (in)	421.0 (16.57)		
Width	mm (in)	392.0 (15.44)		
Height (1)	mm (in)	540.0 (21.26)		
Height (2)	mm (in)	196.0 (7.72)		
Dry Weight	kg (lb)	61.7 (136.0)		

*Specifications are subject to change without notice.

*Dry weight is according to Kubota's standard specification.
When specification varies, the weight will vary accordingly.

DIMENSIONS

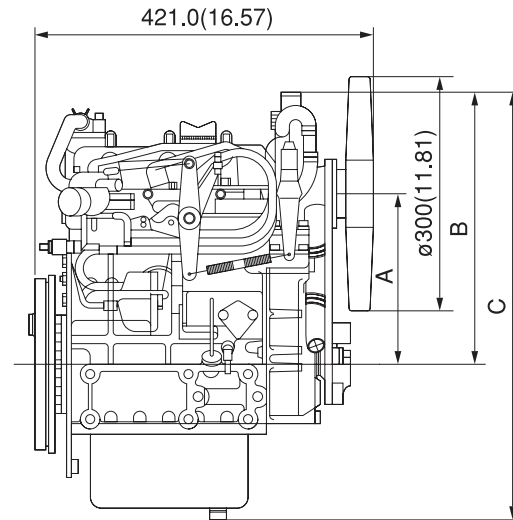

	A	B	C
High Fan Position	215(8.46)	344(13.54)	540(21.26)
Low Fan Position	175(6.89)	305(12.01)	501(19.72)

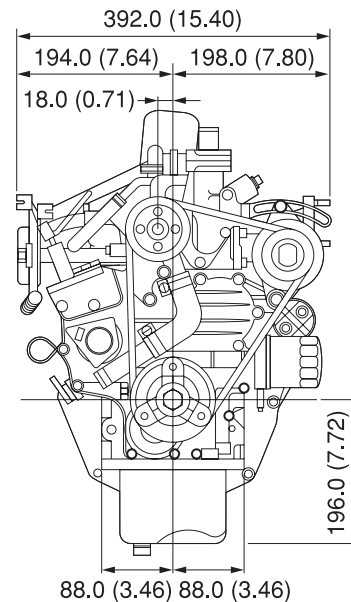

Shown above: with Kubota Standard flywheel and rear-end-plate.
Option kit for Clutch No.6 1/2" Flywheel and
SAE No.5 Flywheel Housing is also available.



KUBOTA Engine America Corporation

505 Schelter Road, Lincolnshire, IL 60069
Phone: 847-955-2500 Fax: 847-955-2699
www.kubotaengine.com