



JOHN DEERE

STAMFORD

www.frontierpower.com

JDS80-T4

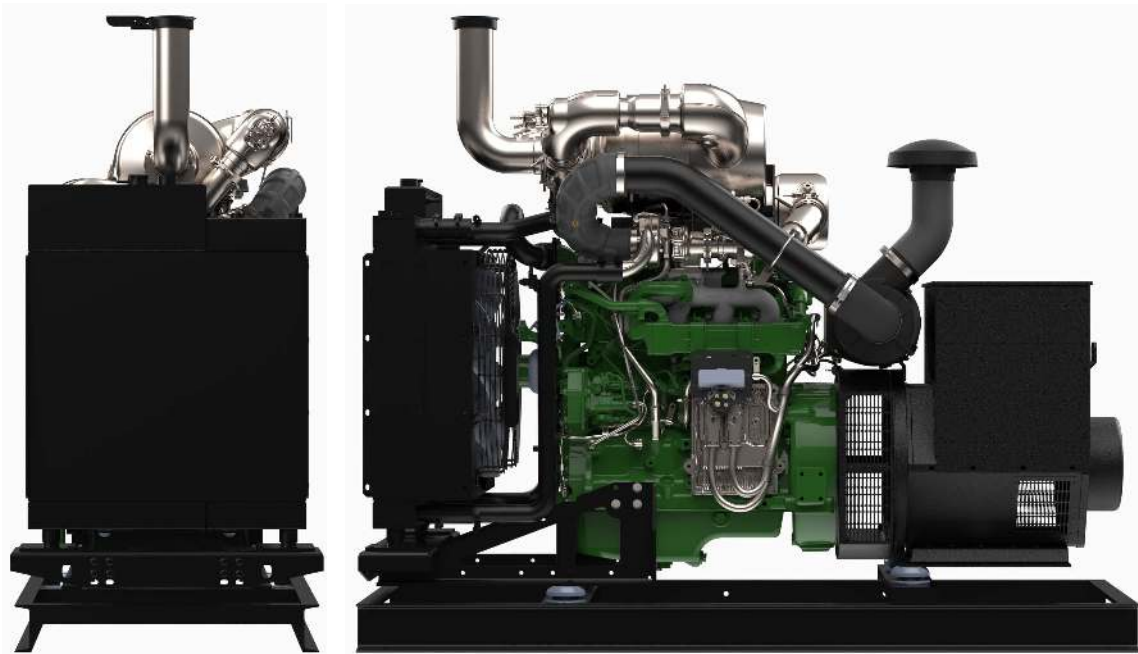

ENGINE

Manufacturer	John Deere
Model	4045HFG04
Output, inter.	99 kWm (133 HP)
Output, cont.	90 kWm (122 HP)
Cylinders	Four
Bore X Stroke	106 mm X 127 mm 4.2" X 5.0"
Displacement	4.5 L (275 in ³)
Compression ratio	17.0:1
Engine weight (dry)	550 kg (1213 lb)

Refer to engine performance curve for more information.

A.C. ALTERNATOR

Manufacturer	Newage/Stamford
Model	UC1274C
Control system	Self excited
Voltage Regulation	AS440 +/-1%
Rated power factor	0.8
Winding Leads	12
Frequency	60 Hz
Temp. Rise	105C/40C
Alternator weight	406 kg (895 lb)

Refer to alternator spec sheet for more information.

GENERATOR SET SPECIFICATIONS

Model	JDS80-T4
Estimated genset weight	1390 kg (3063 lb)
Prime rating	77 kW _e
Standby rating	85 kW _e
Voltages*	208V standard
Operating speed	1800 rpm
Phase	Three
*Alternative voltages available.	

Refer to Frontier Power Products for more information.

STANDARD CONTROLS

- Deep Sea Electronics DSE6110 MKIII digital start panel with all engine parameters, DPF status, and safety shutdowns.
- Panel mounted facing service side (space permitting) or rear on top of alternator.
- Electric fuel transfer and priming pump (12VDC).
- Battery rack and cables (no battery) for 12 VDC starting system.

Specifications are subject to change without notice and should be used as a reference only

DIMENSIONAL DRAWING

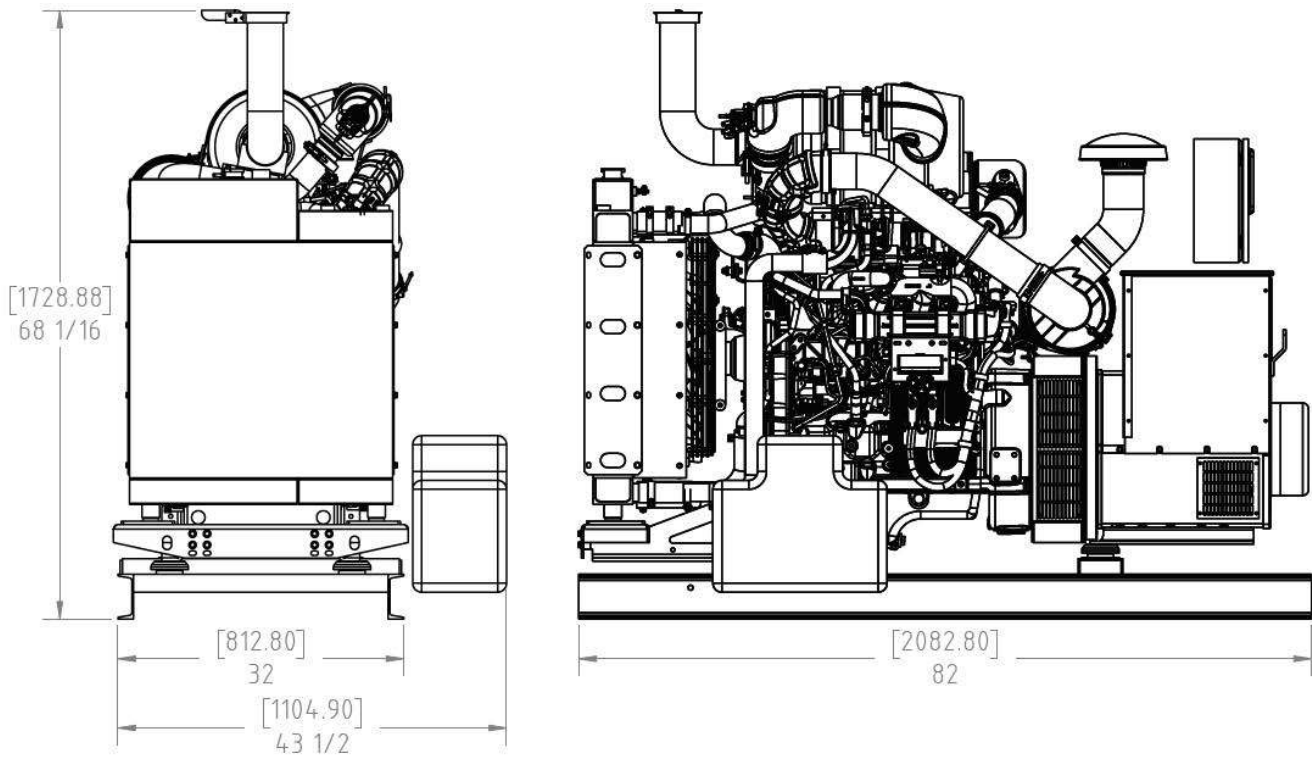

Dimensions subject to change without notice

Dimensions are in format in [mm]

STANDARD ACCESSORIES/ NOTES

- Standard structural steel frame welded with four captive vibration isolator mounts.
- Control panel mounted on service side or rear at or near chest height.
- Control panel comes with heated display to allow cold weather operation down to -40C.
- Battery rack attached to steel frame.
- Unit may require derate dependent on ambient conditions such as >50C or >2225m altitude as well unit installation conditions.

CUSTOMIZATIONS

- Fuel tank sub-frame or day tank.
- Long Run Oil System™ Package
- Standard and custom enclosures (requires alternative frame).
- Transport Canada approved trailer base.
- Custom electrical distribution.
- Remote diagnostics and communication.
- Remote control panel mounting.
- Alternative output ratings, voltages and frequencies available (dependent on engine).

WWW.FRONTIERPOWER.COM

Delta, BC:

(604) 946-5531

TOLL-FREE: 1 877 946-5531

Calgary, AB

(403) 720-3735

TOLL-FREE: 1 877 720-3735

Edmonton, AB

(780) 455-2260

TOLL-FREE: 1 877 455-2260

Winnipeg, MB

(204) 949-1526

TOLL-FREE: 1 877 949-1526